

Nitoseal MS100

constructive solutions

One part, primer-less, non-staining facade sealant

Uses

Nitoseal MS100 has been formulated for stain-free sealing of joints in and around concrete, brick, masonry, pre-cast panels, stone cladding, windows, doors and fibre cement sheeting.

Advantages

- Will not stain masonry, marble or other surfaces.
- Excellent primer-less* adhesion to most common building materials.
- Can be applied to damp substrates
- Fast neutral cure.
- Highly flexible with excellent application characteristics.
- Low odour, environmentally friendly.
- Low modulus and high movement capabilities.
- Excellent UV and weather resistance
- Nitoseal MS100 may be used as a sealant to assist with sound insulation.
- Good adhesion to silicone, polysulphide or polyurethane contaminant.

* Refer to Priming section.

Standard compliance

ISO 11600 Type F 25LM

Description

Nitoseal MS100 is a tough, durable elastomeric joint sealant. It is based upon hybrid silyl modified polyether technology. It is suitable for use over a wide range of external and internal building applications and has excellent weather resistance.

Nitoseal MS100 has excellent primer-less adhesion to a wide range of common building substrates and does not stain concrete, marble and other masonry surfaces.

Properties

Uncured sealant:

Form:	Smooth, non slump paste
Flash point:	>65°C
Solids content:	100% approximately
Application temperature range:	5°C to 50°C
Skinning time:	25 mins, 20°C/50% RH
Cure rate:	3 mm in 24 hrs, 8mm in 7 days 20°C/50% RH



Cured sealant:

Form:	Elastic solid
Colour:	White, Grey, Black, Portland, Buff, Rustic Red
Typical hardness	
Shore 'A' @ 20°C:	20
Modulus classification:	Low
U.V. resistance:	Excellent
Service temperature range:	-40°C to 70°C
MAF:	Butt joints 25% unprimed 50% primed Lap joints 50% unprimed 100% primed

Application Instructions

Preparation

Joint surfaces must be clean and free from frost and rag dry, preferably completely dry. Remove all dirt, laitence, loose materials and foreign matter. Remove all rust, scale and protective lacquers from metal surfaces. Non porous surfaces should be degreased using Fosroc Equipment Cleaner.

In all joints an Expandafoam or Hydrocell XL polyethylene foam backing should be used to prevent sealant contact with the back of the joint, and hence allow optimum performance.

In shallow joints self adhesive debonding tape can be used.

Nitoseal MS100

Priming

Good adhesion can be gained on concrete, timber, metals, ceramics, brickwork and most coating surfaces without the use of primers. On some porous surfaces such as GRC, adhesion will be improved by the use of a primer - refer Fosroc Technical Service for further advice.

Application

Cartridge: Cut the end off threaded stub on cartridge, screw on nozzle and cut nozzle to desired bead size at a 45° angle.

Extrude the sealant firmly into joint to ensure complete contact with joint faces. Smooth finish if necessary with a spatula wetted with a dilute detergent solution.

Cleaning

Clean tools immediately after use with Fosroc Equipment Cleaner.

Overpainting

The practice of overpainting sealants which experience a high degree of movement is discouraged as it can result in premature failure of the sealant.

However, Nitoseal MS100 may be overcoated with water-based elastomeric coatings such as Dekguard Elastic and exterior emulsion paints such as Dekguard W. Tests should be carried out to confirm compatibility of sealant and proposed paint systems.

Nitoseal MS100 should be allowed to cure fully before the application of the coating or paint. For best results the sealant should be allowed to weather prior to overcoating.

Estimating

Nitoseal MS100 is supplied in 380 ml cartridges.

To work out quantities (excluding wastage) use the following formula:

$$\frac{S}{W \times D} = \text{Lineal metres per pack}$$

- S = Packaging size in millilitres
- W = Sealant profile width in millimetres
- D = Sealant profile depth in millimetres

Guide to sealant quantities

Joint size in mm	Litre per metre run	Metre per 0.38 litre cartridge
3 x 5	0.015	25.3
3 x 10	0.030	12.66
5 x 5	0.025	15.2
5 x 10	0.050	7.6
10 x 5	0.050	7.6
10 x 10	0.100	3.8
15 x 10	0.150	2.54
20 x 10	0.200	1.9
25 x 15	0.380	1.0

These are theoretical yields. No allowance has been made for variation in joint dimensions or wastage.

Design criteria

Movement Accommodation Factor (MAF)

The Movement Accommodation Factor is a figure quoted indicating the ability of a sealant to accommodate joint movement throughout the service life of that sealant, expressed as a percentage of the joint width at time of sealing.

To calculate the theoretical / minimum joint width knowing the expected maximum working movement of the joint:

$$W = \frac{M}{MAF/100} + M$$

- W = Joint width
- M = Expected maximum working movement of joint
- MAF = Movement Accommodation Factor of that sealant

For further advice on joint design see BS 6093 :1993.

Nitoseal MS100 may be applied to joints between 5 and 35 mm wide. To minimise stresses imposed on the joint sealant, all moving joints should be designed to an optimum width to depth ratio of 2:1.

This ratio is subject to these overriding minimum sealant depths:

- 5 mm minimum sealant depth at any point.
- 5 mm minimum bonding depth against metals, glass and other non-porous surfaces, providing that joint faces are in good condition.
- 8 mm minimum bonding depth against masonry or other porous surfaces, or any non-porous surfaces where joint faces are in poor condition.

Shear joints shall be a minimum joint width to depth ratio of 1:2 up to a maximum of 1:1. The total movement in shear should not exceed 80% of joint depth at time of sealing in these joints.

Nitoseal MS100

Sealants are now commonly used as weatherseals in place of flashings and scribes around window and door openings. These areas require greater attention to detail and standards of workmanship to perform successfully.

Example of sealed perimeter joint of plastic or metal frame

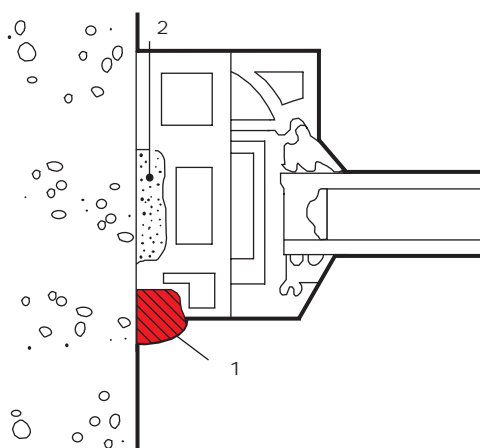

1 Nitoseal MS100 2 Secofoam

Example of brickwork expansion joint

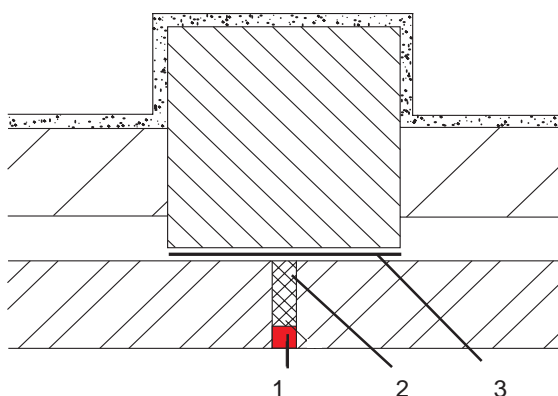

1 Nitoseal MS 100 2 Hydrocell 3 DPM

Example of sealed movement joint in external joint panels

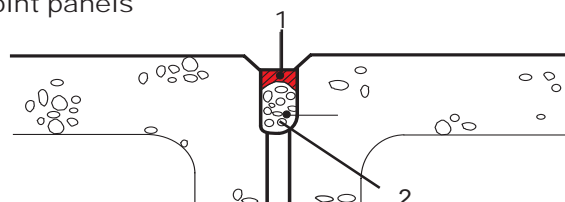

1 Nitoseal MS100 2 Expandafoam cord

Limitations

Nitoseal MS100 **must not** be used as follows:

- Where adhesion is required to polyethylene, polypropylene, polybutylene, polycarbonate and bitumen.
- Where it is subjected to permanent immersion in water.
- With structural glazing or floor joints.
- With pipes or in other applications where it may be subjected to hydrostatic or pneumatic pressures (other than wind pressure).
- Where continual exposure to aggressive solvents or chemicals will occur.
- Where timber or wood based products have been painted.
- Nitoseal MS100 is a combustible material. Do not seal around chimney or flues.
- Do not overpaint with oil based alkyd paint systems.
- Should not be considered a substitute for a good standard of joint preparation.
- Joint arrises should be primed where movement in excess of 25% is expected.

Storage

Cartridges: Shelf life 12 months when sealed and stored in cool, dry conditions.

Health and safety

No significant hazard. For additional information see appropriate Product Safety Data Sheet.



Fosroc Limited

Drayton Manor Business Park,
Coleshill Road, Tamworth,
Staffordshire B78 3TL. UK

www.fosroc.com

Important note

Fosroc products are guaranteed against defective materials and manufacture and are sold subject to its standard Conditions for the Supply of Goods and Services, copies of which may be obtained on request. Whilst Fosroc endeavours to ensure that any advice, recommendation, specification of information it may give is accurate and correct, it cannot, because it has no direct or continuous control over where or how its products are applied, accept any liability either directly or indirectly arising from the use of its products, whether or not in accordance with any advice, specification, recommendation of information given by it.

telephone:
+44 (0) 1827 262222

fax:
+44 (0) 1827 262444

e-mail:
uk@fosroc.com



certificate no. FM 610